

STEPHENS INTERNATIONAL PUBLIC SCHOOL

Holidays Homework for Class – 4th – 2018-19

ENGLISH:

- Q:1. Do 1 page cursive writing in a four lined notebook daily.
Q:2. Read English newspaper and listen to English news daily.
Q:3. Read the chapter 4, 5 & 6 of Main Course Book and find out 10 difficult words from each chapter. Write their meanings and also make sentences.
Q:4. Revise whatever done in the class properly.
Q:5. Complete practice 4, 5 & 6 of Practice Book.

Worksheet

- Q:1 Add a predicate to complete these sentences:-
(a) The doctor _____.
(b) The vegetable seller _____.
(c) My teacher _____.
(d) Sanjay and Sunita _____.
(e) Aeroplanes _____.
- Q:2. Write suitable question words in the blanks:-
(a) _____ is that man?
(b) _____ are you looking for?
(c) _____ bag is yours?
(d) _____ do children like cartoons?
- Q:3. Pick out the nouns in the following sentences:-
(a) Chandigarh is the capital of Punjab.
(b) The Indian army fought bravely.
(c) Gambhir is a good batsman.
(d) Flowers smell sweet.
(e) Abdul lost his ring.
- Q:4. Rewrite the following sentences, using correct punctuation marks:-
(a) be polite
(b) where do you live
(c) please open the door
(d) get off the horse
(e) what a lovely flower
- Q:5. Change the following sentences into interrogative ones:-
(a) I want some money.
(b) He loves mankind
(c) She liked red roses.
(d) They danced joyfully.
(e) Boys ran down the street.
- Q:6. Underline adjectives in the given sentences:-
(a) She is a beautiful girl.
(b) Kamini is a beautiful lady.
(c) Devinder is a handsome boy.
(d) Madras is a big city.
(e) I like Chinese food.
- Q:7. Write suitable adjectives in the blanks:-
(a) He did not eat _____ rice.
(b) Krishna is an _____ girl.
(c) Flowers give out _____ smell.
(d) This book contains _____ stories.
- Q:8. Use the following adjectives in sentences:-
(a) red (b) small (c) pretty
(d) difficult (e) late (f) unhappy
- Q:9. Fill in the blanks with suitable reflexive pronouns:-
(a) I _____ shall do this.
(b) The child hurt _____.
(c) She _____ broke the desk.
(d) We enjoyed _____ there.
(e) You _____ ruined your family.
- Q:10. Fill in the blanks with demonstrative pronouns:-
(a) _____ is a true story.
(b) _____ is a baseless.
(c) _____ is my purse.
(d) _____ are lovely flowers.
(e) _____ are green trees.
- Q:11. Fill in the blanks with interrogative pronouns:-
(a) _____ deceived you?
(b) _____ are you waiting for?

STEPHENS INTERNATIONAL PUBLIC SCHOOL

Holidays Homework for Class – 4th – 2018-19

- (c) _____ is the capital of India.
- (d) _____ do you want?
- (e) _____ were you speaking to?

Q:12. Fill in the blanks with plurals:-

- (a) Two _____ entered our house. We caught one **thief** on the spot.
- (b) My **watchman** is honest. He is not dishonest like other _____.
- (c) This is a very big **box**. It has three small _____ inside it.
- (d) You save his **life**. I will save many more _____.
- (e) This **child** is different from many other _____ of my class.

Q:13. Rewrite the following sentences by changing the nouns and pronouns to the opposite gender:-

- (a) The son loves his father.
- (b) He saw a lion and bull.
- (c) The bride cut the cake.
- (d) The maid cooked the food.
- (e) The poet married a widow.

Q:14. Write antonyms of the following:-

- (a) agree (b) bright (c) junior (d) punish
- (e) accept (f) busy (g) arrival

Q:15. Write synonyms:-

- (a) foolish (b) loyal (c) buy (d) end (e) begin

Q:16. With the help of the given hints, write two paragraphs on 'The Role of Internet'.

Age of computers — internet — international computer network — advantages to businessmen, students, teachers — tele-conferencing — can be misused — terrorists use it for nefarious activities — electronic crimes.

HINDI

fun3k % I kQ rFkk I qj dk; ZdjA dk; Zdsfy, , d vyx i flrdk yxk, j rFkk feM&VeZ dh 0; kdj .k ; kn djA
 ç% - fuEu 'kCnka ea l s vutokj] vuqkfl d rFkk vkr 'kCnka dh vyx&vyx I ph cuk, A

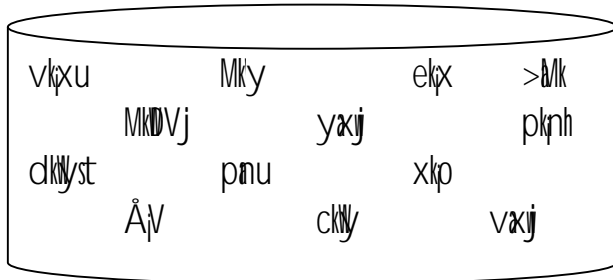

vutokj	vuqkfl d	vxr
&&&&&&&&	&&&&&&&&	&&&&&&&&
&&&&&&&&	&&&&&&&&	&&&&&&&&
&&&&&&&&	&&&&&&&&	&&&&&&&&
&&&&&&&&	&&&&&&&&	&&&&&&&&

ç% - I kK 'kCnka dh yMh cuk, A

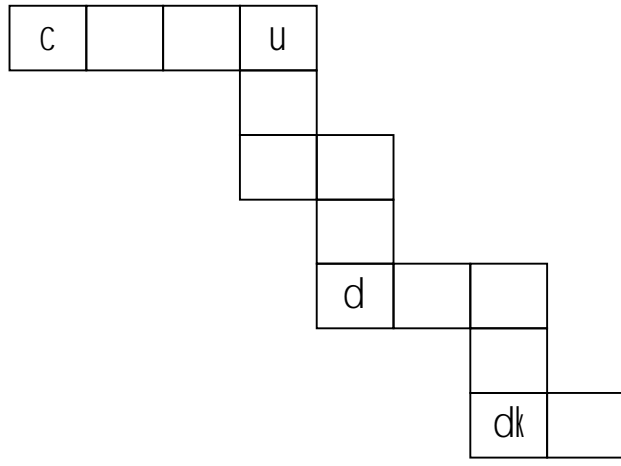

STEPHENS INTERNATIONAL PUBLIC SCHOOL

Holidays Homework for Class – 4th – 2018-19

Q:2. Complete this table about Maya's teeth

	Upper Jaw	Lower Jaw	Total
Incisors	4		8
Canines		2	4
Premolars	4		8
Molars			8
	14	14	28

Q:3. The picture (figure2 shown above) shows Maya's temporary teeth. Label it correctly using these words: 4 incisors, Canine, 2 premolars.

Q:4. If you chew your food well, your mouth will make a lot of saliva. Why is this good for you?

Q:5. Collect different types of cloth pieces and paste them on your scrapbook. Mention their types.

Q:6. Prepare a scrapbook of dry leaves and identify the plant using the leaf. Mention their names. (10 leaves)

Q:7. Make a model showing molecular arrangement in solid, liquid and gas with the help of thermocol.

Q:8. Revise the syllabus of Pre Mid-Term.

SOCIAL SCIENCE

Q:1. Paste the pictures in scrapbook depicting the life of people in Rajasthan.

Q:2. Make a list of the problems that the people living in desert areas face.

Q:3. Collect the different types of soil, put them in small packets and paste in scrapbook with their names.

Q:4. Write about the minerals found in each state of the Southern Plateaus.

Q:5. Enjoy your holidays by visiting Manda Zoo and click pictures of animals you see and paste them on scrapbook.

Q:6. Make a collage on scrapbook of 5 natural and man-made resources that we use everyday.

Q:7. On a map of India, mark different forests of India and paste in scrapbook.

Note:- Use 1 scrapbook for the entire work

COMPUTER

Q:1. Make the collage on 'Input and Output devices'. Collect the pictures from the magazines, newspapers or internet. And make the collage on scrapbook.

Q:2. Name three types of printers and also explain them and paste their pictures.

Q:3. Collect the pictures of all windows and paste it on a scrapbook and also write the features of Window 10.

Q:4. Write a short note on storage devices and also explain the various storage devices.

Q:5. Differentiate between a file and a folder.

Note:- Do your homework on scrapbook.

Learn lessons done in the class.

URDU

• Complete page no. 4, 5, 6 and 7 on your notebook.

• Learn these questions for test after vacations.

ART & CRAFT

Q:1. Make flower vase by using waste at home.

Note:- Learn Pre Mid-Term syllabus of all subjects.

Enjoy your holidays and have fun.